



BaySpec's all new DeepView® Fourier or Spectral-Domain OCT Spectral Engine is an InGaAs line scan camera with an integrated VPG®-based Spectrograph simultaneously covering multiple wavelengths for precise and rapid optical coherence tomography measurements.

The DeepView® Spectral Engine provides convenience for researchers and OEM users assembling Fourier or spectral-domain optical coherence tomography (SD-OCT), white light interferometry (WLI) or infrared spectroscopy systems. This flat-field spectral analyzer design is based on highly efficient transmission *Volume Phase Grating* (VPG®) and mounts on an ultra-fast digital line scan camera. The spectral engine accepts single-mode fiber optic inputs and is customizable via grating inserts to match the spectral bandwidth and center wavelength of the users' light source.

DeepView™ SWIR Series spectral engine shown with example camera

The OCTS SWIR Series spectral engine employs a highly efficient *Volume Phase Grating* (VPG®) as the spectral dispersion element and an ultra-sensitive InGaAs array detector as the detection element, thereby providing high-speed parallel processing and continuous spectrum measurements. The signal is spectrally dispersed with the VPG®, and the diffracted field is focused onto an InGaAs array detector. The control electronics read out the processed digital signal to extract required information. Both the raw data and the processed data are available to the host.

Applications:

- High-speed spectral OCT for cancer detection in the biologically interested wave bands of 0.8-2.2 μm range
- High-resolution NIR spectral OCT in retinal diagnostics and measurements in ophthalmology
- Spectral OCT guidance on implant and surgery
- High speed and fast turn-around Spectral OCT assessment of surgical outcome
- Catheter/Endoscopic SD OCT image guided diagnostics, image-guided surgery, and image-guided therapy
- In vivo and in vitro general medical diagnostics and imaging
- In vivo and in vitro operation room and surgical procedure Quality Assurance
- Non-invasive skin cancer and skin disease diagnostics and detection
- Industrial applications such as non-destructive testing

Key Features:

- Rugged and reliable spectrometer featuring no moving parts
- Highly-efficient, high-resolution Volume-Phase Grating®
- Flexible options for center wavelength and spectral bandwidth, selectable at time of order; contact factory for custom solutions and packaging with user camera.
- Grating and optical bench customizable for your light source and application
- Single-mode fiber coupled inputs; other input fiber options available

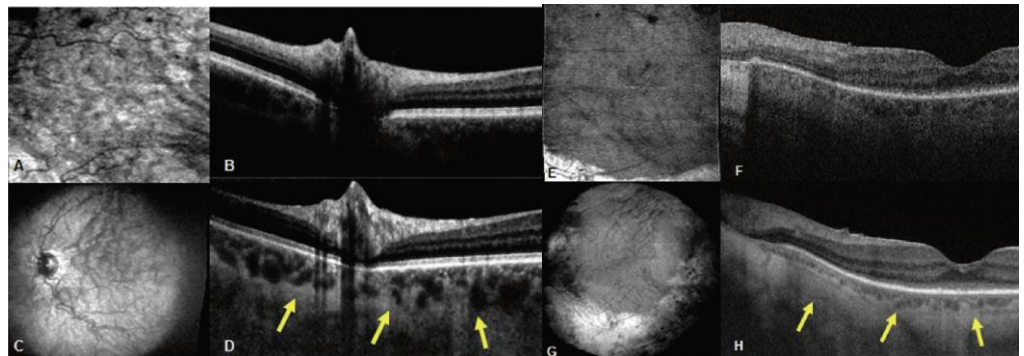

3D Optical Coherence Tomography (OCT) at 800 and 1060nm of (A)–(D); a normal retina and (E)–(H) a patient with retinitis pigmentosa. (A, E) En-face zoomed-in fundus image of the choroid using 1060nm 3D OCT. Arrows indicate enhanced choroidal visualization. (Courtesy Cardiff University)

Parameter	Specification
Optical	
Image plane size ¹	26 mm wide
Optical spot size (single mode fiber)	25 μm diameter
Aperture (f#)	f/4
Focal length (nominal)	100 mm
Mechanical	
Length x Width x Height:	260 x 240 x 116 mm ³ Height includes fiber mount and camera mounting plate size subject to change based on specifications
Weight:	< 800 g (spectrograph only) < 450 g (camera)
Fiber optic interface	Keyed FC/APC (inquire about PM or alternate types)
Camera compatibility	SU1024LDH2-1.7RT-0500/LC, inquire on other types
Camera mount	Optional

¹with single-mode fiber input (core diameter of 9 μm)

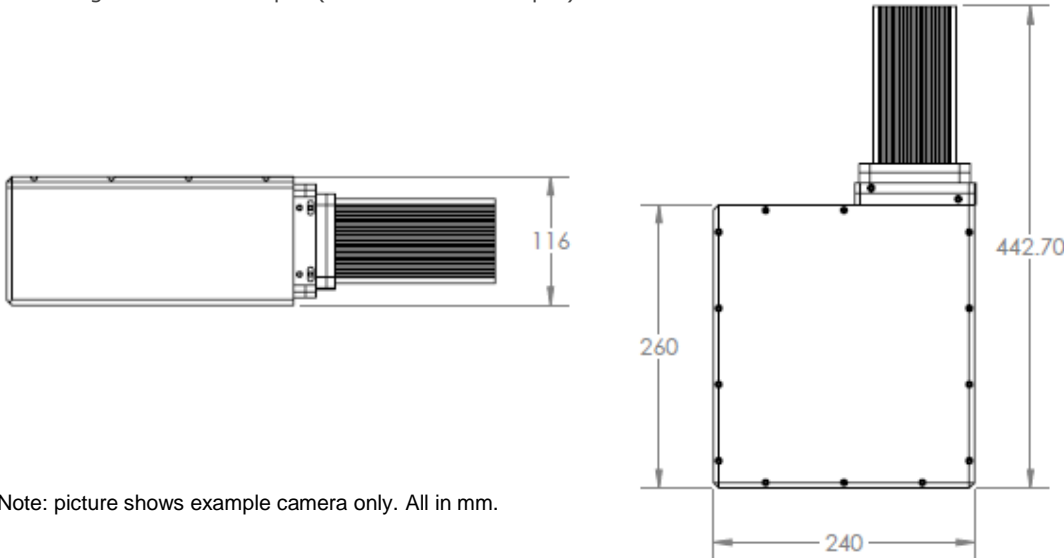

Note: picture shows example camera only. All in mm.

Ordering Information:

(grating options – ordering suffix², other options by request)

	-1280-1310-1340
Center wavelength (nm)	1310
Bandwidth (nm) ³	60 or custom
Wavelength range (nm)	1280 (0px) – 1340 (~1024px)
Wavelength dispersion (nm _{avg} /pixel) ⁴	0.05
Wavelength dispersion (nm _{avg} /mm)	1.95
Stray light(% of peak 100 pixels away) ⁵	0.1%

²Spectrometer model number is OCTS-XXX-YYY-ZZZ; Replace YYY with nominal center wavelength; replace XXX with starting wavelength; ZZZ for ending wavelength

³Over 20 mm image plane

⁴With 10 μm pixel pitch

⁵Test laser wavelengths used: 800 nm, as appropriate for grating option selected

Specifications are subject to change without notice

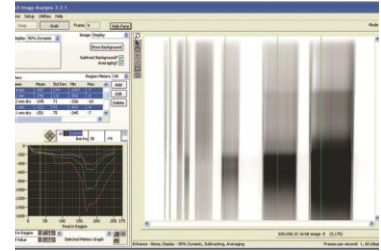

Image Analysis Software with each spectral engine purchase

Consider using with:

- Fast Digital Line Scan Cameras, we can customize to any available model
- Mini-Wide Light Sources
- ASE Light Sources
- Fiber-optic Bundles & Accessories

